

## Polyethylene caps K50S

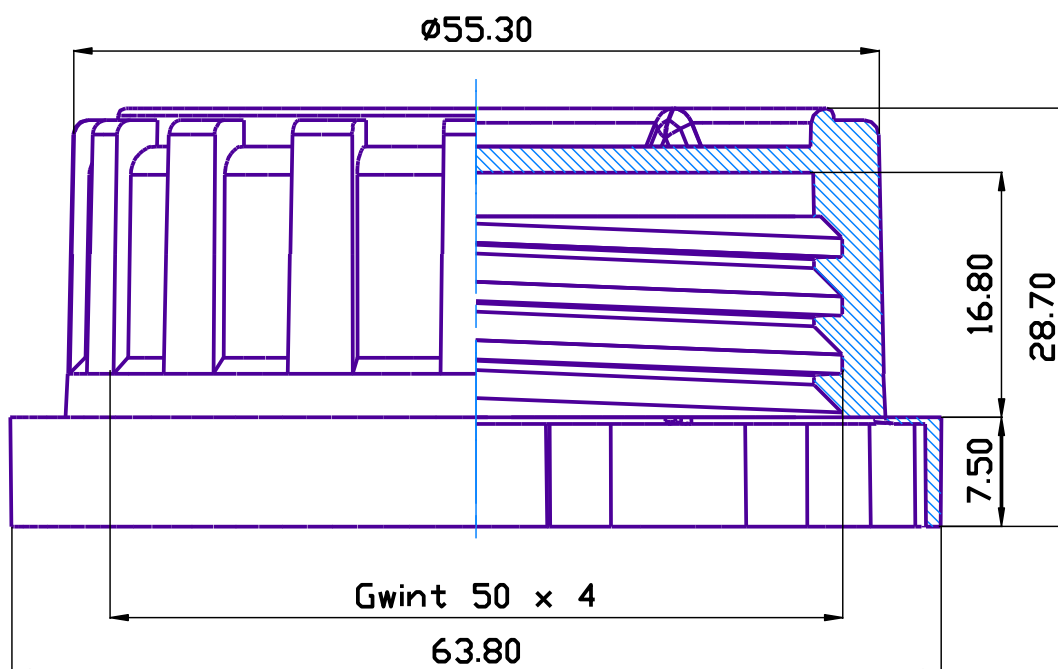

Self-sealing cap made of HDPE polyethylene with insert used for induction sealing or polyethylene foam insert used for sealing of PE or PP containers. Such containers are used in pharmaceuticals, chemical and food processing industry. Standard glue or glue with sanitary certificate are used for applying the insert to the cap.

Coding:

K50S /

	<b>U</b> – induction sealing
	<b>P</b> – polyethylene sealing
<b>B</b>	– white pigmented cap
<b>N</b>	– blue pigmented cap
<b>C</b>	– red pigmented cap
<b>Y</b>	– yellow pigmented cap
<b>Z</b>	– green pigmented cap

Packed in boxes (800 pieces).

Business section:

e-mail: [marketing@nsautomatyka.com.pl](mailto:marketing@nsautomatyka.com.pl)

**Producing in accordance with the ISO 9001:2000 quality control**